

2.4GHZ 0.5 WATT TRANSMIT/RECEIVE ZIGBEE RFeIC

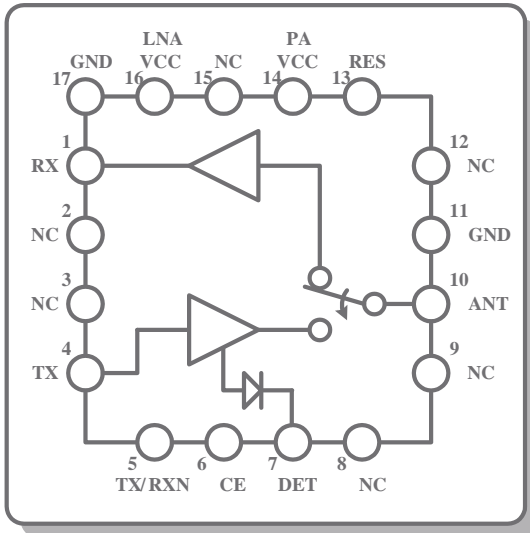

Description

The RFX2401H is a fully integrated, single-chip, single-die RFeIC (RF Front-end Integrated Circuit) which incorporates all key RF functions needed for a wide range of wireless applications including IEEE 802.15.4, ZigBee and Bluetooth EDR, in the 2.4GHz ISM band. The RFX2401H architecture integrates the PA, LNA and associated matching networks, Transmit/Receive switching circuitry, and a harmonic filter, all in a BiCMOS single-chip device. This RFeIC is designed to provide up to half-watt transmit power at the antenna.

The combination of high performance, high efficiency, low noise and superior receive sensitivity, small form factor, and low cost makes RFX2401H the ideal solution for multiple applications including automatic metering, smart Home Area Network and other 2.4GHz systems requiring extended range of operation and robust link performance. The power detector circuit is also integrated.

Applications

- ▶ Wireless Metering
- ▶ Smart Home Area Networking
- ▶ Factory/Inventory Automation
- ▶ Wireless Voice and Video
- ▶ ZigBee-Based Systems
- ▶ Other 2.4GHz ISM Systems

Parameters	Value	Conditions
TX		
Small-Signal Gain	30dB	In-band, Typical, TX Enabled
Max Output Power	+27dBm	In-band, Typical, TX Enabled (4.0 VDC)
Output P1dB	+25dBm	In-band, Typical, TX Enabled (4.0 VDC)
Large Signal Current	350mA	+27dBm Output Power, TX Enabled
Quiescent Current	75mA	TX Enabled, No RF Applied
2 nd / 3 rd Harmonic	-30 / -25dBc	+25dBm Output Power, TX Enabled
Noise Figure	4.5dB	All Conditions, TX Enabled
RX		
Small-Signal Gain	15dB	In-band, Typical, RX Enabled
Noise Figure	2.6 dB	In-band, Typical, RX Enabled
Input P1dB	0dBm	In-band
Quiescent Current	8mA	RX Enabled
CHIP		
Operating Frequency	2.4-2.5GHz	TX or RX Enabled
Supply VCC	3.0 – 4.5 VDC	5V Max
Shut-down Current	0.05uA	Standby
Input Output Return Loss	-10dB	RF Ports, Typical, In Band
RF Port Impedance	50-Ohm	Single-ended
Control Signals	High Enable	CMOS Logic, <0.3V Low, >1.2V High
Package	16-QFN	3.0mm x 3.0mm x 0.5mm

RFeIC® is a registered trademark of RFaxis, Inc. All rights reserved.

This product brief is a general list of parameters to provide information on the capabilities of this device and is subject to change without notice.