

2.4GHZ HIGH POWER TRANSMIT/RECEIVE WLAN RFIC

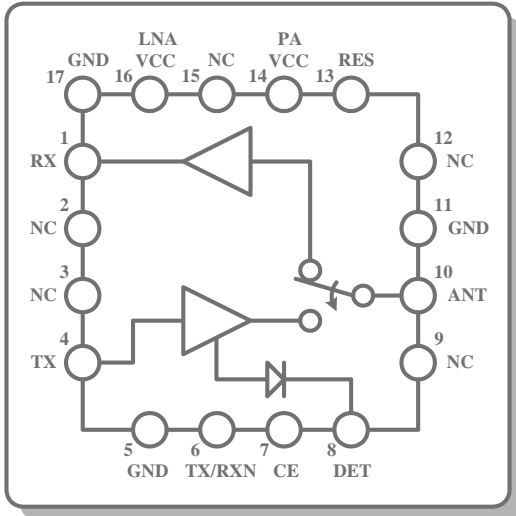

Description

The RFX2402H is a fully integrated, single-chip, single-die RFIC (RF Front-end Integrated Circuit) which incorporates all the RF functionality needed for today's wireless communications. The RFX2402H architecture integrates the PA, LNA, Transmit and Receive switching circuitry, the associated matching networks, and harmonic filters all in a BiCMOS single-chip device.

This RFIC is designed for use in 802.11b/g/n AP/Router applications operating at 2.4GHz requiring medium to high output power. Combining superior performance, high sensitivity and efficiency, low noise, small form factor, and low cost, the RFX2402H is the ideal solution for single antenna applications, and the ideal building block for MIMO applications. RFX2402H has simple and low-voltage CMOS control logic, and requires minimal external components for system implementation. The PA power detect circuit is also integrated.

Applications

- ▶ 802.11b/g/n Access Point
- ▶ 802.11b/g/n High Power Devices
- ▶ 802.11b/g/n Multimedia Devices
- ▶ Other 2.4GHz Transceivers

Parameters	Value	Conditions
TX		
Small-Signal Gain	28dB	In-band, Typical, TX Enabled
Output P1dB	+27dBm	In-band, Typical, TX Enabled (4.5 VDC)
Quiescent Current	65mA	Typical, TX Enabled, No RF Applied
Linear Output Power 1	+21dBm	802.11g/n 54Mbps OFDM EVM < 3.5%
Linear Output Power 2	+24dBm	802.11b 1Mbps CCK Mask Compliance
Linear Output 1 Current	180mA	+21dBm at ANT
2 nd / 3 rd Harmonic	-40 / -40dBc	+24dBm Output Power
Noise Figure	4.5dB	All Conditions, TX Enabled
RX		
Small-Signal Gain	15dB	In-band, Typical, RX Enabled
Noise Figure	2.6 dB	In-band, Typical, RX Enabled
Input P1dB	0dBm	In-band
Quiescent Current	8mA	RX Enabled
CHIP		
Operating Frequency	2.4-2.5GHz	TX or RX Enabled
Supply VCC	2.7 – 4.5 VDC	5V Max
Shut-down Current	0.05uA	Standby
Input Output Return Loss	-10dB	Typical, In Band
RF Port Impedance	50-Ohm	Single-ended
Control Signals	High Enable	CMOS Logic, <0.3V Low >1.2V High
Package	16-QFN	3.0mm x 3.0mm x 0.5mm

RFIC® is a registered trademark of RFaxis, Inc. All rights reserved.

This product brief is a general list of parameters to provide information on the capabilities of this device and is subject to change without notice.