

5GHz TRANSMIT / RECEIVE WLAN CMOS RFEIC

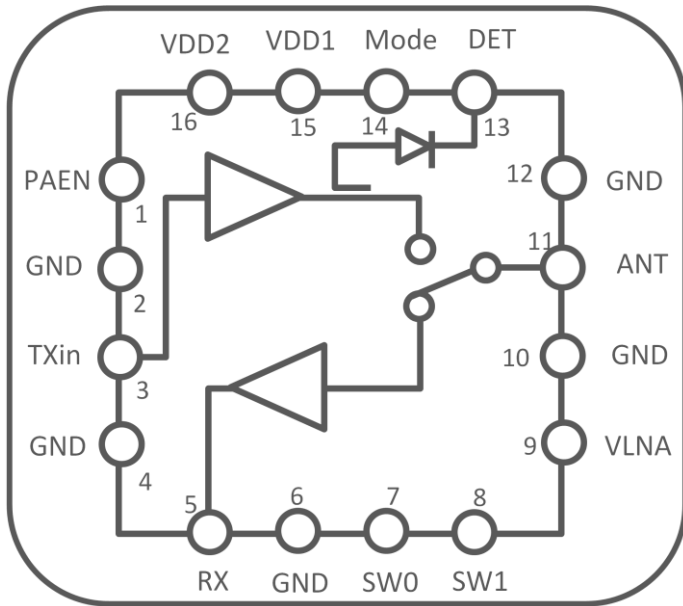

Description

RFX5000 is a fully integrated, single-chip, single-die RFEIC (RF Front-end Integrated Circuit) which incorporates all the RF functionality needed for a typical IEEE 802.11a/n WLAN system operating in the 4.9-5.85GHz range. The RFX5000 architecture integrates the PA, LNA, Transmit and Receive switching circuitry, the associated matching network, and the harmonic filter all in a CMOS single-chip device. Combining superior performance, high sensitivity and efficiency, low noise, small form factor, and low cost, the RFX5000 is the ideal solution for single antenna applications, and the ideal building block for 802.11n MIMO applications for wireless HDTV and other high-performance video streaming solutions.

RFX5000 has simple and low-voltage CMOS control logic, and requires minimal external components including only the external power supply bypass and the desired band-pass filter for the receive path. A directional coupler based power detect circuit is also integrated for accurate monitoring of output power from the PA.

Applications

- ▶ 802.11n Access Point
- ▶ 802.11n NIC PC Card
- ▶ 802.11n Multimedia Applications
- ▶ 802.11n Mobile Platforms
- ▶ 802.11a Devices
- ▶ Other 5GHz Transceivers

Parameters	Typical	Conditions
TX		
Small-Signal Gain	30dB	High Linearity Mode
Quiescent Current	120mA	
Linear Output Power	+17dBm	EVM<3%, 802.11a 64QAM/54Mbps, High Linearity Mode
Linear Output Current	195mA	+17dBm at ANT
2 nd and 3 rd Harmonic	-42dBm/MHz	802.11a OFDM Signal, P _{OUT} +17dBm at ANT
RX		
Small-Signal Gain	12dB	
Noise Figure	2.7dB	
Input P1dB	-3dBm	
Quiescent Current	8mA	P _{OUT} < -10dBm
CHIP		
Operating Frequency	4.9-5.9GHz	
Supply VDD	2.7 – 3.6 V	
Shut-down Current	0.1uA	
Input Output Matching Return Loss	-10dB	Typical, In-band
RF Port Impedance	50-Ohm	Single-ended
Control Signals	High Enable	CMOS Logic, <0.3V Low, >1.2V High
Package	16-QFN	3.0mm x 3.0mm x 0.45mm

RFIC® is a registered trademark of RFaxis, Inc. All rights reserved.

This product brief is a general list of parameters to provide information on the capabilities of this device and is subject to change without notice.