

5GHZ HIGH POWER TRANSMIT/RECEIVE WLAN RFEIC

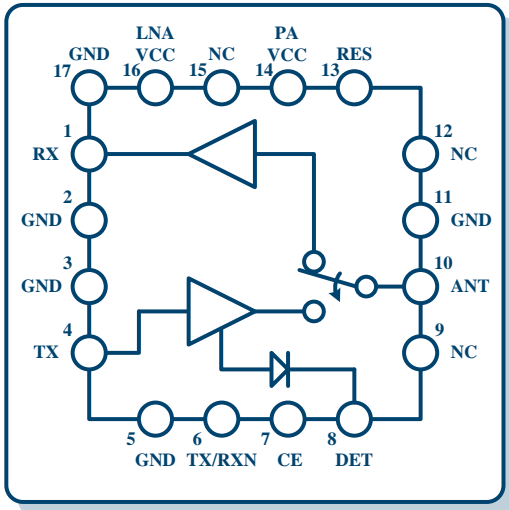

Description

The RFX5000H is a fully integrated, high power, single-chip, single-die RFEIC (RF Front-end Integrated Circuit) which incorporates all the RF functionality needed for today's wireless communications. The RFX5000H architecture integrates the PA, LNA, Transmit and Receive switching circuitry, the associated matching network, and the harmonic filter all in a BiCMOS single-chip device. This RFEIC is designed for use in high power 802.11n applications operating at 5GHz. Combining superior performance, high sensitivity and efficiency, low noise, small form factor, and low cost, the RFX5000H is the ideal solution for single antenna applications, and the ideal building block for MIMO applications. RFX5000H requires minimal external components including the external power supply bypass and the desired band-pass filter for system performance. The PA power detect circuit is also integrated.

Applications

- ▶ 802.11n Access Point
- ▶ 802.11n Mobile Platforms
- ▶ 802.11n NIC PC Card
- ▶ 802.11a Devices
- ▶ 802.11n Multimedia Applications
- ▶ Other 5GHz Transceivers

Parameters	Value	Conditions
TX		
Small-Signal Gain	28dB	In-band, Typical, TX Enabled (4.5VDC)
Output P1dB	+28dBm	In-band, Typical, TX Enabled (4.5 VDC)
Quiescent Current	115mA	TX Enabled, No RF Applied
Linear Output Power	+22dBm	802.11a/n 54Mbps OFDM EVM < 3.5%
Linear Output Current	225mA	+22dBm at ANT
2 nd and 3 rd Harmonic	-40dBc	+22dBm Output Power
Noise Figure	5dB	All Conditions, TX Enabled
RX		
Small-Signal Gain	10dB	In-band, Typical, RX Enabled
Noise Figure	3.8dB	In-band, Typical, RX Enabled
Input P1dB	0dBm	In-band
Quiescent Current	10mA	RX Enabled
CHIP		
Operating Frequency	4.9-5.95GHz	TX or RX Enabled
Supply VCC	2.7 - 4.5 VDC	5.5V Max
Shut-down Current	5uA	Standby
Input Output Matching Return Loss	-10dB	Typical, In-band
RF Port Impedance	50-Ohm	Single-ended
Control Signals	High Enable	<0.3V Low, >1.2V High
Package	16-QFN	3.0mm x 3.0mm x 0.5mm

RFelC® is a registered trademark of RFaxis, Inc. All rights reserved.

This product brief is a general list of parameters to provide information on the capabilities of this device and is subject to change without notice.